

DUAL CHANNEL DIGITAL CONTROLLER

TTM-1020 SERIES



DUAL CHANNEL
DIGITAL
CONTROLLER
TTM
1020
SERIES

Most advanced Dual Channel Digital Controller, Temperature & Humidity Controller, Cascade Controller and Remote Input Controller in compact style with various functions.

■Features

●Independent dual channel input provided.

Each input of thermocouple, R.T.D., thermistor, current, voltage is operated by two independent selections.

●5 options are selective in event output of TTM-1920

"SV change (3 selections available)", "RUN / READY" and various measured values are easily set as event output.

●Positioning Proportional Control installed.

Input from feedback and Positioning Proportional Control are available.

●Blind Function

Each kind of parameter is necessarily unable to be shown. When in use, only requested parameters can be set and indicated. Furthermore, this function enables operators to avoid their error-setting and to have their originality.

●Accuracy and sampling utilized for various products.

Sampling time (output changing time): 0.1sec.
Indicator accuracy: 0.1%

●Communication function installed.

The extension cable is as long as 500m and the connection use is up to 31 products at a time. The concentrating control is supplied for all data collection and change of each setting value with a host-computer.

■Front Panel

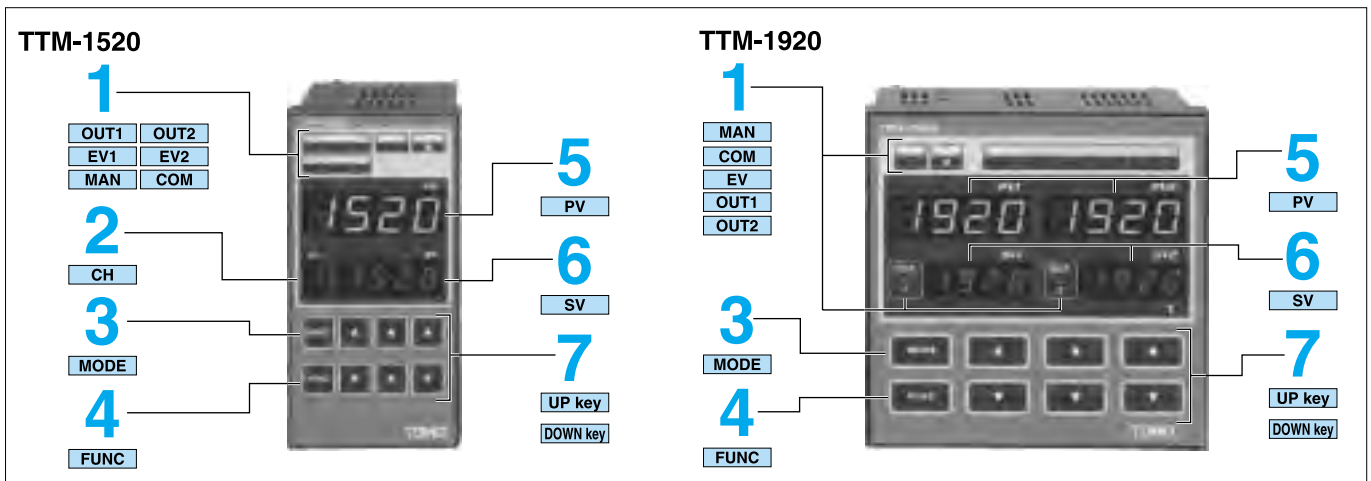

1	OUT1	Monitor lamp (Relay , SSR drive output only)	OUT2	Monitor lamp (Relay , SSR drive output only)
	EV1	Event output · Output 1 monitor (Action lamp)	EV2	Event output · Output 1 monitor (Action lamp) (1→2)
	MAN	Manual action monitor (Action lamp)	COM	Showing communication operating time.
2	CH	Indication of channel.	5	PV Process valuable indication, character indication (Event output, PID etc.)
3	MODE	Mode key (all mode key characters) ●When mode key is pressed, display at mode-side will be shown. ●When you press mode key for more than 2 seconds, display at parameter side will be shown.	6	SV Setting value indication, monitor of manipulation variable.
4	FUNC	A change of Auto / Manual and others.	7	▲ / ▼ key ●Setting / change of SV value and release a start of At. ●Setting / change of Event output value.●A change and selection of other functions. ●Key is in accordance with each digit, and feeding of each digit is automatic.

Explanation of Feature

Event Output

There are two utilization for setting of event output; 1) deflection-event-output to change output point with alteration of setting point 2) absolute-value-event-output with fixed output value not being changed by alteration of setting point.

1 Deviation high and low limit.

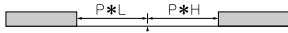

2 Deviation high limit.

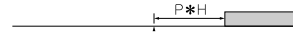

3 Deviation low limit.

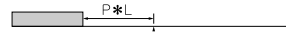

4 Deviation high and low range.



5 Absolute value high and low limit.

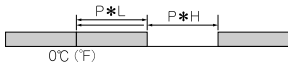

6 Absolute value high limit.



7 Absolute value low limit.

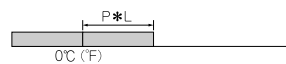

8 Absolute value high and low limit range.

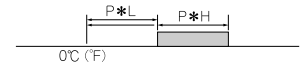

Blind Function

The screens of the blind function is not indicated after the setting. (The blinding can be released.) This function is usable to protect the parameters from being changed by the operator.

The mode screen or the parameter screen whichever you require are unable to be displayed by pressing a key. The screen can be locked, since a locking function is provided. When the SV screen is turned out, the set value is not normally indicated but the process value is only shown.

Initial mode

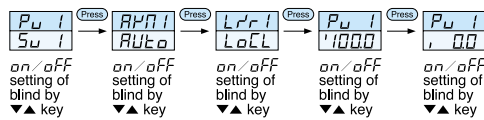

This blind function can be applied to all unlocked parameters.

Set up mode

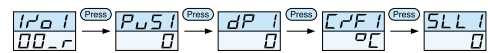

Control definition mode



Various controls

- 2 Channels control...Independent control of 2 channels for each 2 of inputs and outputs.
- Cascade control...2 inputs and 1 output utilized.
- Heating and Cooling control...1 input and 2 outputs utilized.
- Temperature and Humidity control...Wet and dry bulb control by R.T.D. input.
- Positioning proportional control...Input by feed back resistance.
- Remote control...By remote SV input.

Terminals

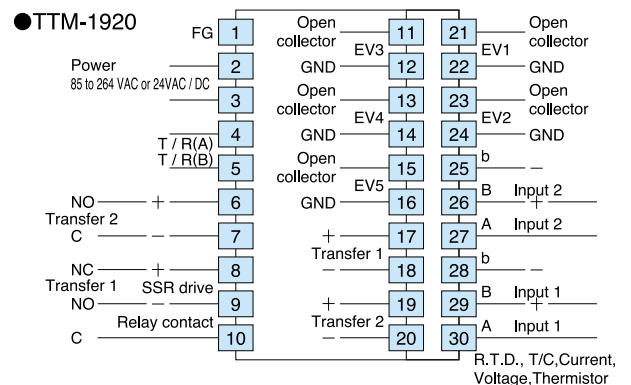
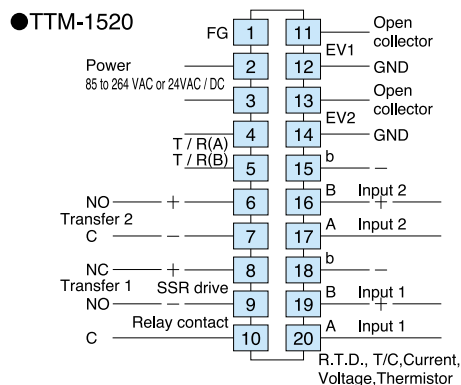

Explanation of terminals

F.G	Connect to ground	SSR drive	Connect to + and - of Input on SSR side directly.
DI	No polarity	Transmission	Connect while paying attention to polarity (+, -).
Communication	Connect T/R(A) and T/R(B) terminals correctly. (Use transducer except RS-485.)	EV1 to 5	Output at normal open contact
SG	Use as a signal for communication.	R.T.D. input	Connect the terminals A, B, and b.
Relay output	C: Common NO: Normal open NC: Normal close	T/C, current, and voltage input	Connect to polarity (+, -).

Both event input 1 & 2 and event output 1 & 2 can be selected automatically by the key on the front panel. In case of input SV2, output is open collector.

※ T/C : Thermocouple

Input and These Ranges

(Range for input of thermocouple, R.T.D., current, and voltage are adjustable in the arranges given below.)

Thermocouple		Setting range		Display range	
		Non decimal point	With decimal point	Non decimal point	With decimal point
K (JIS/IEC)	°C	0~1300	0.0~999.9	-40~1372	-40.0~999.9
	°F	0~2500	0.0~999.9	-40~2501	-40.0~999.9
J (JIS/IEC)	°C	0~800	0.0~800.0	-31~850	-31.0~850.0
	°F	0~1450	0.0~999.9	-24~1563	-24.0~999.9
E (JIS/IEC)	°C	0~800	0.0~800.0	-27~833	-27.0~833.0
	°F	0~1450	0.0~999.9	-16~1531	-16.0~999.9
T (JIS/IEC)	°C	-200~400	-199.9~400.0	-231~407	-199.9~407.0
	°F	-330~750	-199.9~750.0	-385~765	-199.9~765.0

Thermocouple		Setting range		Display range	
		Non decimal point	With decimal point	Non decimal point	With decimal point
N (IEC)	°C	0~1300	0.0~999.9	0~1335	0.0~999.9
	°F	32~2350	32.0~999.9	32~2435	32.0~999.9
W5Re/W26Re (ASTM)	°C	0~2300	—	0~2336	—
	°F	32~4200	—	32~4236	—
R (JIS/IEC)	°C	0~1700	—	0~1755	—
	°F	32~3100	—	32~3192	—
S (JIS/IEC)	°C	0~1700	—	0~1730	—
	°F	32~3100	—	32~3146	—

R.T.D.		Setting range	Display range
Pt100 (JIS/IEC)	°C	-199.9~500.0	-199.9~539.1
	°F	-199.9~950.0	-199.9~999.9
JPt100 (JIS)	°C	-199.9~500.0	-199.9~529.0
	°F	-199.9~950.0	-199.9~984.4

Current/Voltage	Setting range	Display range
4~20mA DC 1~5V	-1999~9999 or -199.9~999.9	SLL approx. -12% to SLH approx. +12% within setting range
0~10VDC 0~1V 0~10mV 0~5V	-19.99~99.99	SLL approx. -2% to SLH approx. +10% within setting range

Thermistor		Setting range	Display range
Type A	°C	0~100	-30~150
	°F	32~212	-22~302
Type B	°C	50~80	-20~230 ※ -20°C~0°C & 200°C~230°C : Out of accuracy
	°F	122~356	-4~446 ※ -4°F~32°F & 392°F~446°F : Out of accuracy
Type C:D	°C	100~280	-20~310 ※ -20°C~50°C & 300°C~310°C : Out of accuracy
	°F	212~536	-4~590 ※ -4°F~122°F & 572°F~590°F : Out of accuracy
Type H	°C	-10~50	-30~100
	°F	14~22	-22~212

Humidity/Angle of opening	Setting range	Display range
Humidity	10~90%RH(Dry bulb temp.0~99°C)	5~99%RH
Angle of opening	None	-10~90%

Event Mode

Code of PV event

□	None
!	Deviation high and low limit
2	Deviation high limit
3	Deviation low limit
4	Deviation high and low range
5	Absolute value high and low limit
6	Absolute value high limit
7	Absolute value low limit
8	Absolute value high and low range

The above-mentioned event output modes are able to be set for the dual channel respectively.

Also an output mode can be set for the channel 1 and 2.

Additional function of event

□	None
!	Holding
2	Awaiting sequence
3	Abnormal input
4	Holding and awaiting sequence
5	Holding and abnormal input
6	Awaiting sequence and abnormal input
7	Holding and awaiting sequence and abnormal input

When output function mode is 0, only 0,1,2,and 4 are usable.

Example for Wiring Diagram

●Positioning proportional

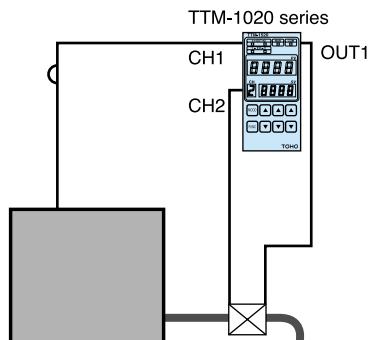

The valve is controlled by output 1 and 2 with feedback resistance from input channel 2.

●Temperature and Humidity Control

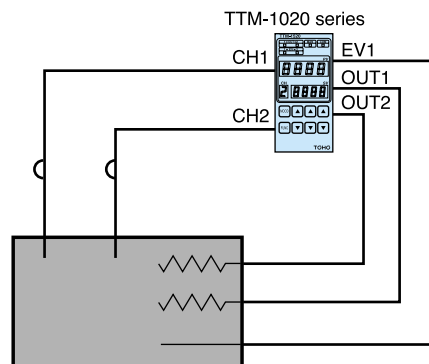

Each wiring connection - channel 1 and dry bulb temperature, channel 2 and wet bulb temperature, output 1 and heating heater, output 2 and humidifier control and event 1 and cooler for dehumidify can be operated for temperature-humidity control.

Standard Specifications

Input	Thermocouple	K, J, E, T, R, S, N, W5Re / W26Re	Selectable for your demand by front key.
	R.T.D.	Pt100, JPt100	
	Thermistor	TOHO A, B, C, D and H type specified.	
	Voltage	0 to 5 VDC, 1 to 5 V, 0 to 1V, 0 to 10V, 0 to 10mV	
	Current	4 to 20mA DC	
Indication	PV (Character)	4 digits, 7 segments, LED, Green 10mm high	
	SV (Setting value)	4 digits, 7 segments, LED, Red, green 8mm high	
	AL, OUT, CH, AV, COM	LED : Red (AL1, AL2, OUT1, OUT2, CH, AV), LED : Green (COM) No CH indication in TTM-1920	
Control Methode	PID Autotuning	Proportional band (P)	0.1 to 200.0% of setting limiter span (It is operated ON / OFF at 0.0)
		Cooling side proportional band(PC)	0.1 to 10.0xP (When heating / cooling)
		Reset time (Integral)	0 to 3600 sec (0 : OFF)
		Rate time (Deviation)	0 to 3600 sec (0 : OFF)
		Cycle time (T, TC)	1 to 120 sec
		Dead band (DB)	+10% of max. at setting limiter span
	ON / OFF	Control sensitivity(C, CC)	0.0 to 10.0% of setting limiter span
Control Output	Relay contact	250 VAC, 3A (Load resistance) 1a contact	
	SSR drive voltage	0 to 12 VDC (Load resistance: 600Ω or more)	
	Voltage	1 to 5 V, 0 to 10 VDC (Load resistance: 1kΩ or more)	
	Current	4 to 20 mA/DC (Load resistance: 600Ω or less)	
Sampling Time	0.1 sec (Output change period is the same.)		
Setting and Indication Accuracy	Thermocouple	±(0.1% + 1 digit) of FS	
	R.T.D	±(0.1% + 1 digit) of FS	
	Thermistor	±(0.1% + 1 digit) of FS	
	Current / Voltage	±(0.1% + 1 digit) in setting limiter span	
Memory Element	EEPROM		
Source Voltage	85 to 264 VAC (Free power source), 24V ±10% AC / DC (Made to order)		
Weight	TTM-1520 Less than 250g, TTM-1920 Less than 350g		
Power Consumption	TTM-1520 Less than 17VA (264VAC) / Less than 8VA (24VAC) / Less than 5W (24VDC) TTM-1920 Less than 18VA (264VAC) / Less than 8VA (24VAC) / Less than 5W (24VDC)		
Accessories	Instruction manual and fittings for installation.		
Operating Condition	0 to 55°C, 35 to 85% RH (No condensation)		
Storage Condition	-20 to 65°C, 35 to 85%RH (No condensation)		
Functions	Manipulated variable limiter (MLL, MLH)	-10.0 to 110% (Relay, SSR drive voltage output: 0.0 to 100.0%)	
	Setting limiter (SLL, SLH)	See "Input, and setting and display ranges". (Minimum set range is 50 digits.)	
	Switching of control mode (CNT)	PID↔ON / OFF. Normal↔Reverse (In case of heat / cool, it is fixed)	
	PV correction (PVS)	-10 to +10% of setting limiter span	
	Manual reset (PBB)	0.0 to 100.0% of proportional band	
	Blind function	It is possible not to display any screen as desired by operation of key.	
	Shift of decimal point (DP)	Be able to change of display of under decimal position without thermocouple input.	
	°C / °F switchable (C / F)	Can be switched for thermocouple and resistance thermometer input only.	
	Input switchable	Be able to change in thermocouple and in R.T.D., not to change to R.T.D. from T / C and it reverse.	
	Key lock	6 modes	
	Watch dog function	Data checked by EEPROM (Err0), A / D converter check (Err1), and autotuning. Built-in watch dog timer	

Optional Function

Specifications	
Event (EV1~EV5)	Event Output : PV Event 7 modes Event Input : SV Switchable, RUN / 2 modes of READY
Transfer Output	Voltage output : 1 to 5 VDC, 0 to 10 VDC, 0 to 10 mVDC (±0.3% of full span) Current output : 4 to 20 mA DC (±0.3% of full span)
Communication	Conforms to RS-485 : Multi-drop 2-line or 3-line system. 1: 31 addressee stations max Communication parameter : Check BBC / or not, 7 bit or 8 bit data, No parity / an uneven number / an even number, stop bit 1 / 2 Communication speed : 1200 / 2400 / 4800 / 9600 BPS Communication address : 1 to 99 Response delay time : 0 to 250 mSEC Local : Changeable

